

Note Finder 1

First Guide Notes

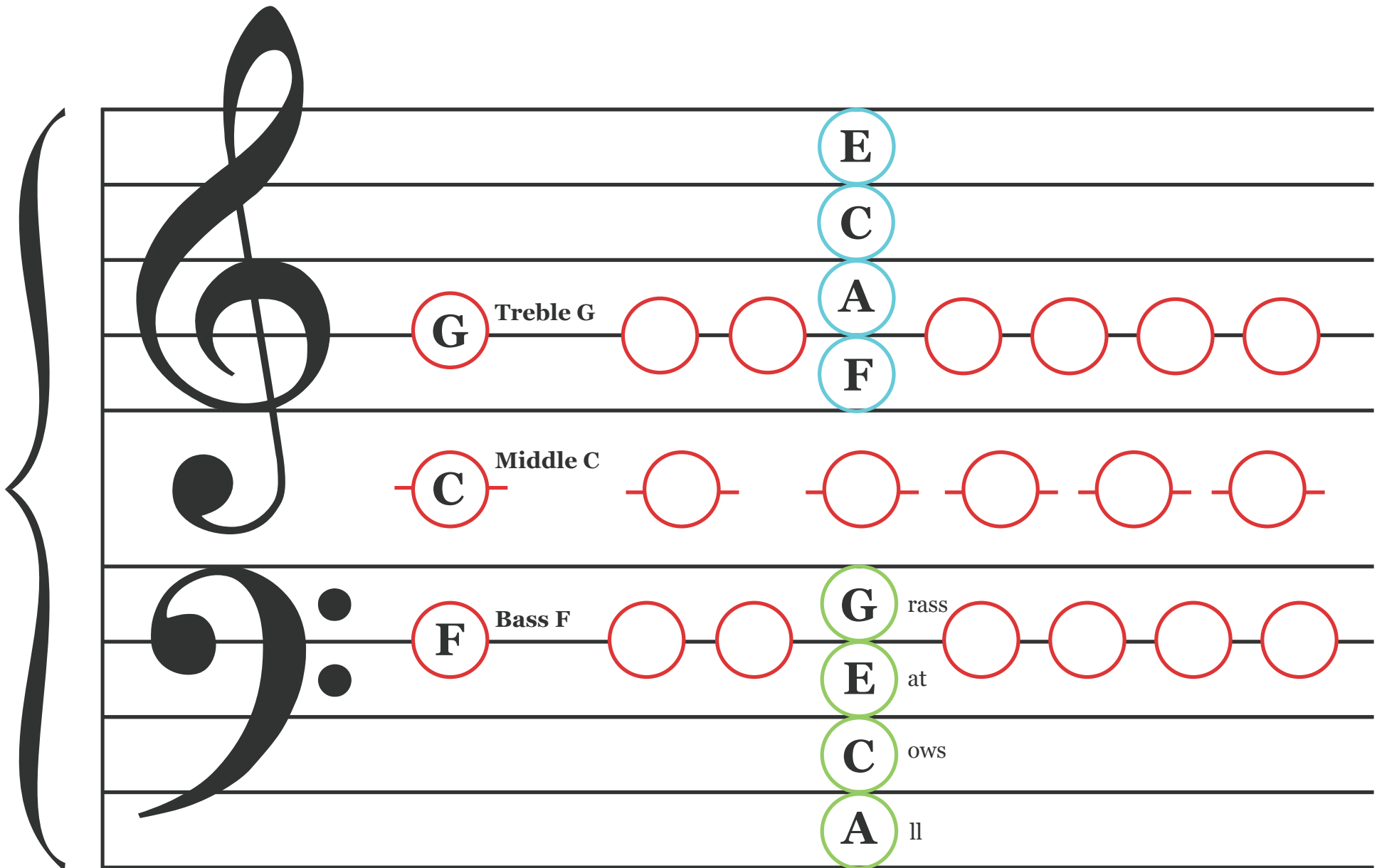

The image shows a musical staff with five lines. On the left, there is a large brace grouping the staff. The top two lines have a treble clef, and the bottom three lines have a bass clef. The notes are as follows:

- Line 5 (top): E (circled in blue)
- Line 4: C (circled in blue)
- Line 3: G (circled in red) Treble G, followed by two empty red circles, then A (circled in blue), followed by four empty red circles.
- Line 2: C (circled in red) Middle C, followed by five empty red circles.
- Line 1 (bottom): F (circled in red) Bass F, followed by two empty red circles, then G (circled in green) rass, followed by four empty red circles.
- Line 4: E (circled in green) at
- Line 3: C (circled in green) ows
- Line 2: A (circled in green) ll

Note Finder 2

Alphabet on the Staff

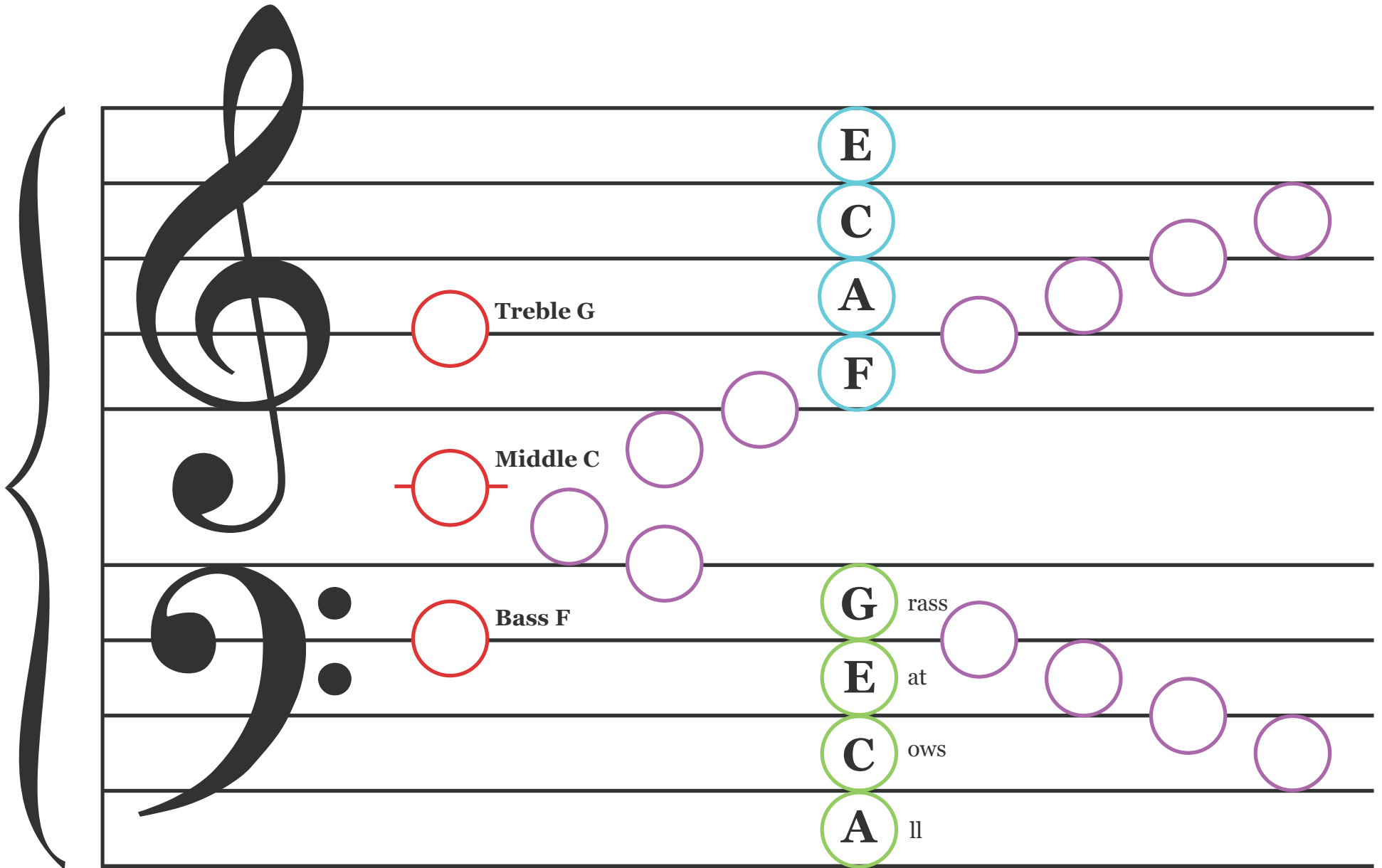

The image shows a grand staff with four staves. The top two staves are grouped by a brace on the left and feature a treble clef. The bottom two staves are grouped by a brace on the left and feature a bass clef. Three red circles are placed on the staves to indicate specific notes: one on the first line of the treble clef (labeled "Treble G"), one on the first space of the middle staff (labeled "Middle C"), and one on the first space of the bass clef (labeled "Bass F"). A vertical column of four cyan circles is positioned on the right side of the staff, containing the letters E, C, A, and F from top to bottom. A vertical column of four green circles is positioned on the right side of the staff, containing the letters G, E, C, and A from top to bottom. To the right of these lettered circles are the words "rass", "at", "ows", and "ll" respectively. Several purple circles are scattered across the staves, representing other notes in the alphabet.

Note Finder 3

Guide Notes Master (Easy)

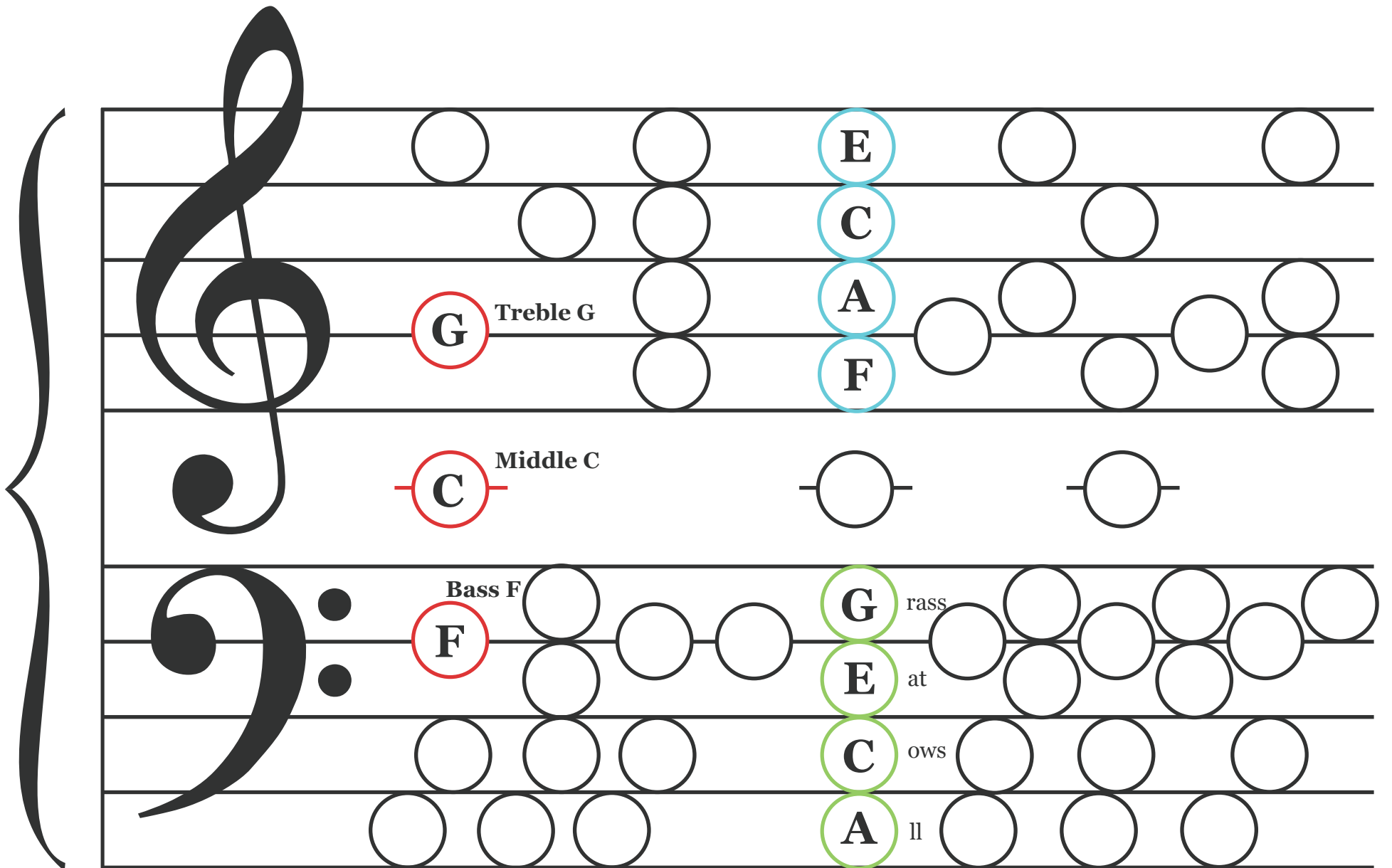

A musical staff with a treble clef on the left and a bass clef on the right. The staff is divided into two sections by a brace on the left. The treble clef section has four staves, and the bass clef section has four staves. A piano keyboard layout is overlaid on the staves. The notes G, C, A, and F in the treble clef section are circled in red. The notes C, G, E, and A in the bass clef section are circled in green. The notes G, C, A, and F are labeled with their respective letters and names: Treble G, Middle C, Bass F, Grass G, Cat E, Cows C, and All A.

G Treble G

C Middle C

F Bass F

G Grass

E Cat

C Cows

A All

Note Finder 4

Notes Near Middle C (Easy)

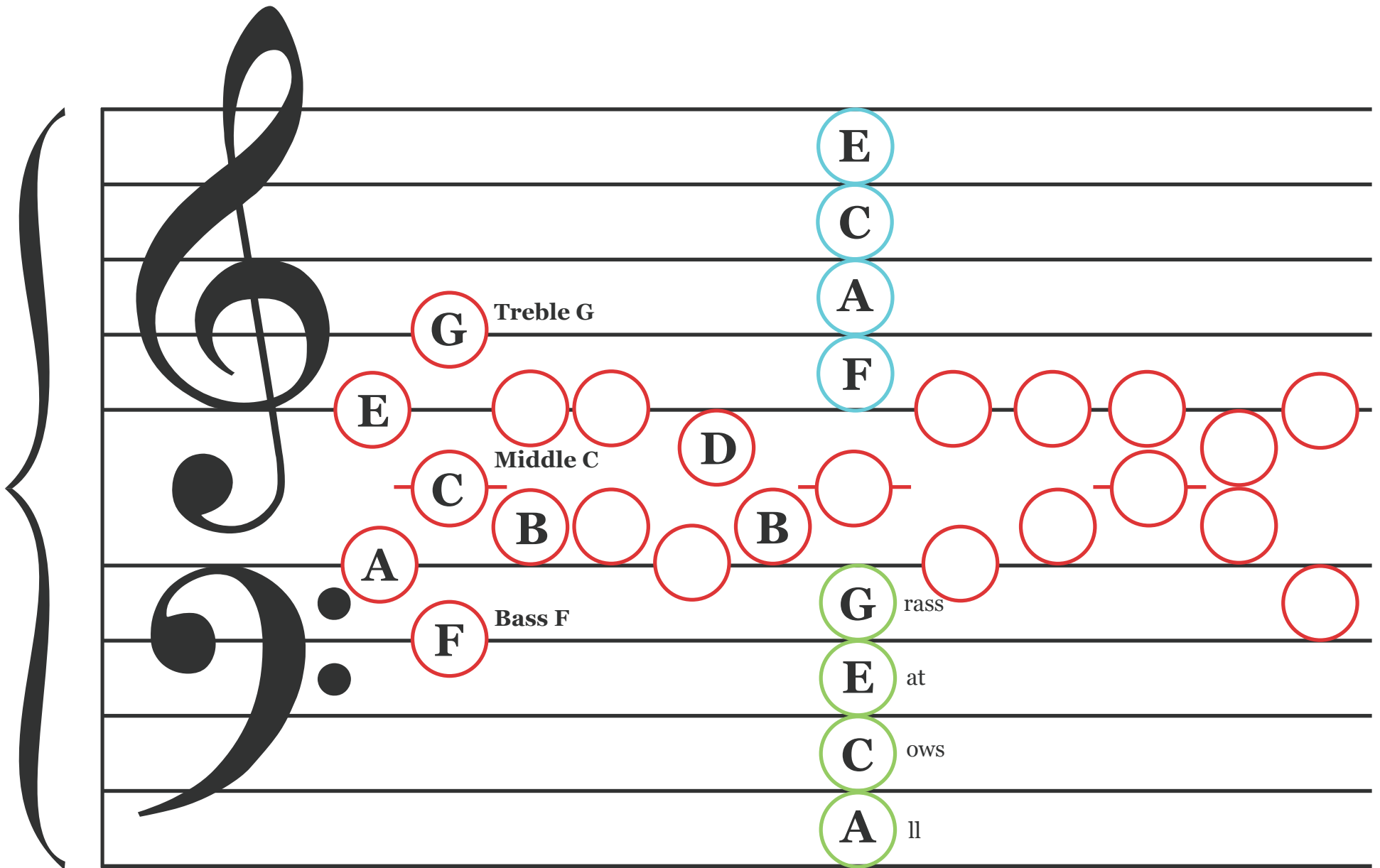

A musical staff with a treble clef and a bass clef. The staff is divided into two systems of four lines each. The notes are arranged as follows:

- Treble Clef (Top System):**
 - Line 4: E (circled in light blue)
 - Line 3: C (circled in light blue)
 - Line 3: A (circled in light blue)
 - Line 2: F (circled in light blue)
 - Line 2: G (circled in red, labeled "Treble G")
 - Line 1: E (circled in red)
- Bass Clef (Bottom System):**
 - Line 4: G (circled in light green, labeled "Bass G")
 - Line 4: E (circled in light green, labeled "at")
 - Line 4: C (circled in light green, labeled "ows")
 - Line 4: A (circled in light green, labeled "ll")
 - Line 3: C (circled in red, labeled "Middle C")
 - Line 3: D (circled in red)
 - Line 3: B (circled in red)
 - Line 2: A (circled in red)
 - Line 2: B (circled in red)
 - Line 1: F (circled in red, labeled "Bass F")

There are several empty red circles scattered across the staff, representing other notes in the range.

Note Finder 5

Steps Down

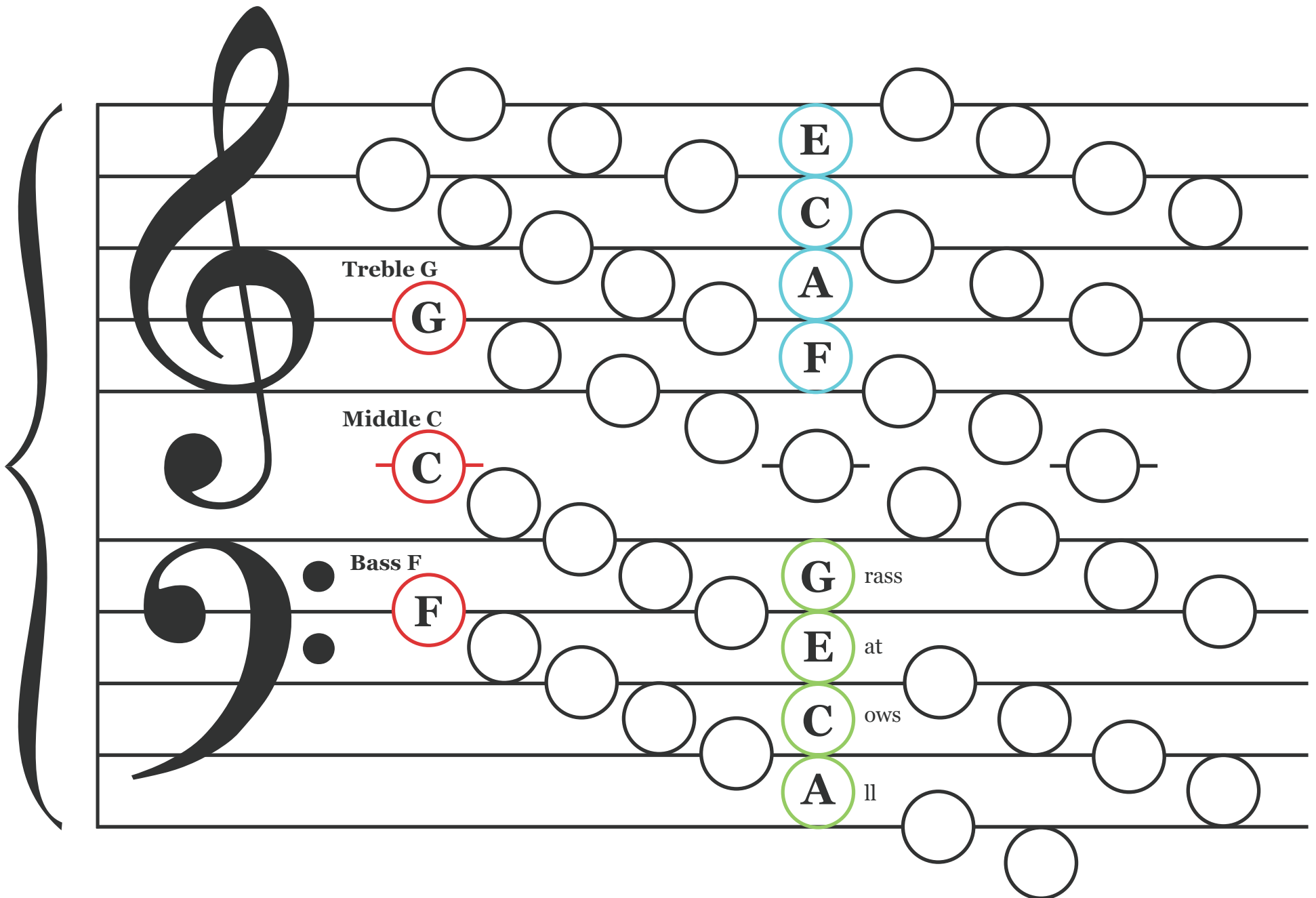

A musical staff with a grand staff (treble and bass clefs) and a piano keyboard layout. The notes are arranged in a descending sequence from top to bottom. The notes are labeled with letters: E, C, A, F, C, G, F, C, A. The labels are: Treble G, Middle C, Bass F, G rass, E at, C ows, A ll. The notes are arranged in a descending sequence from top to bottom. The notes are labeled with letters: E, C, A, F, C, G, F, C, A. The labels are: Treble G, Middle C, Bass F, G rass, E at, C ows, A ll.

Staff	Line	Note	Label
Treble Clef	5	E	E
	4	C	C
	3	A	A
	2	F	F
	1	C	C
Bass Clef	4	G	G rass
	3	E	E at
	2	C	C ows
	1	A	A ll
	5	F	F

Note Finder 6

Skips Up On Staff

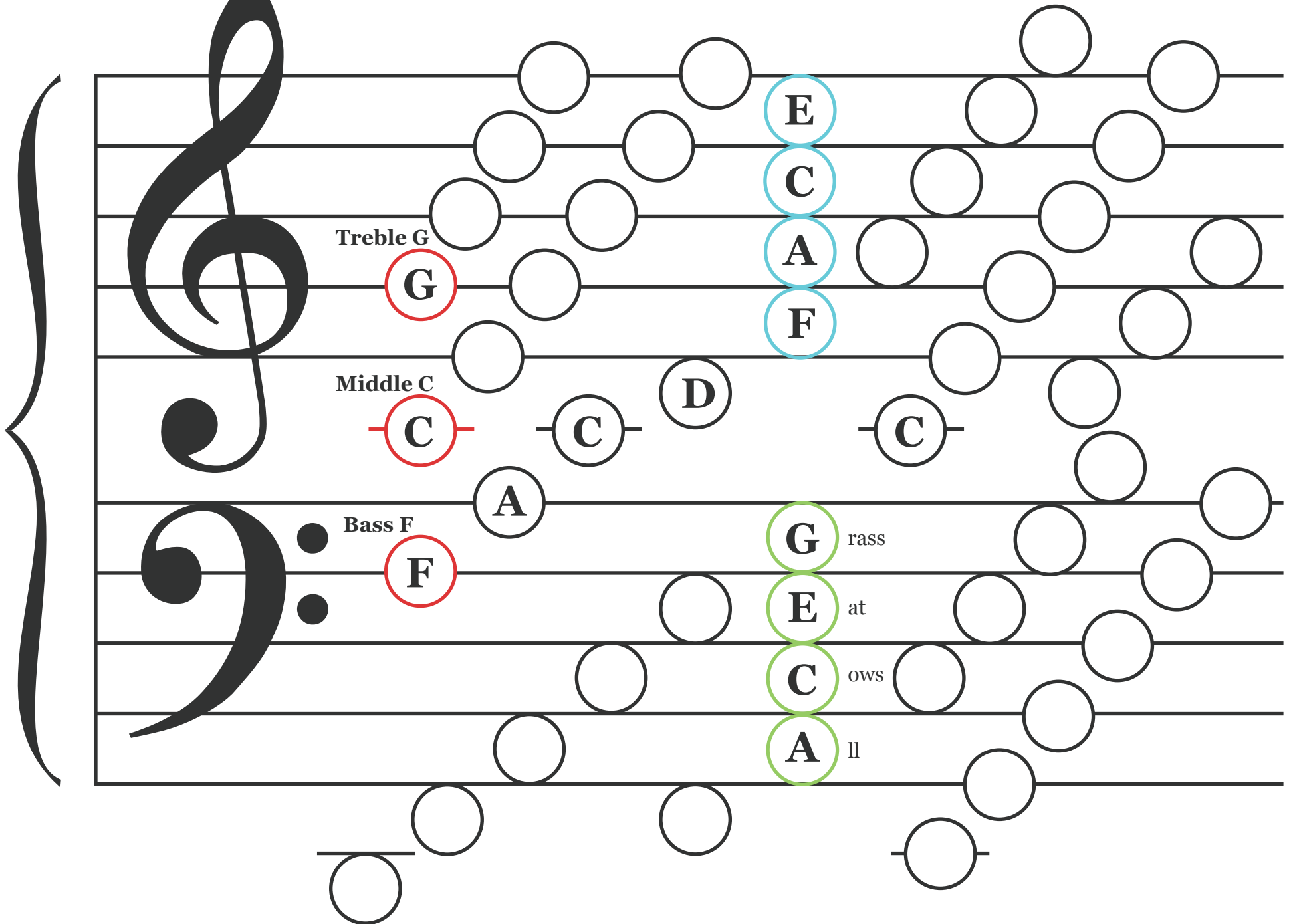

A musical staff with a treble clef and a bass clef. The staff is divided into two systems. The top system (treble clef) has a red circle around the note G on the second line, labeled "Treble G". The bottom system (bass clef) has a red circle around the note F on the second line, labeled "Bass F". In the middle of the staff, there are notes C, C, D, and C, with the first C circled in red and labeled "Middle C". On the right side of the staff, there are four notes circled in cyan: E on the top line, C on the first space, A on the second line, and F on the first space. Below these, there are four notes circled in green: G on the second line, E on the first space, C on the second space, and A on the first space. The notes G, E, C, A, F, G, E, C, A are arranged in a sequence that corresponds to the letters in the word "Grass".

Treble G

Middle C

Bass F

Grass

at

ows

ll

Space Notes 7

Medium

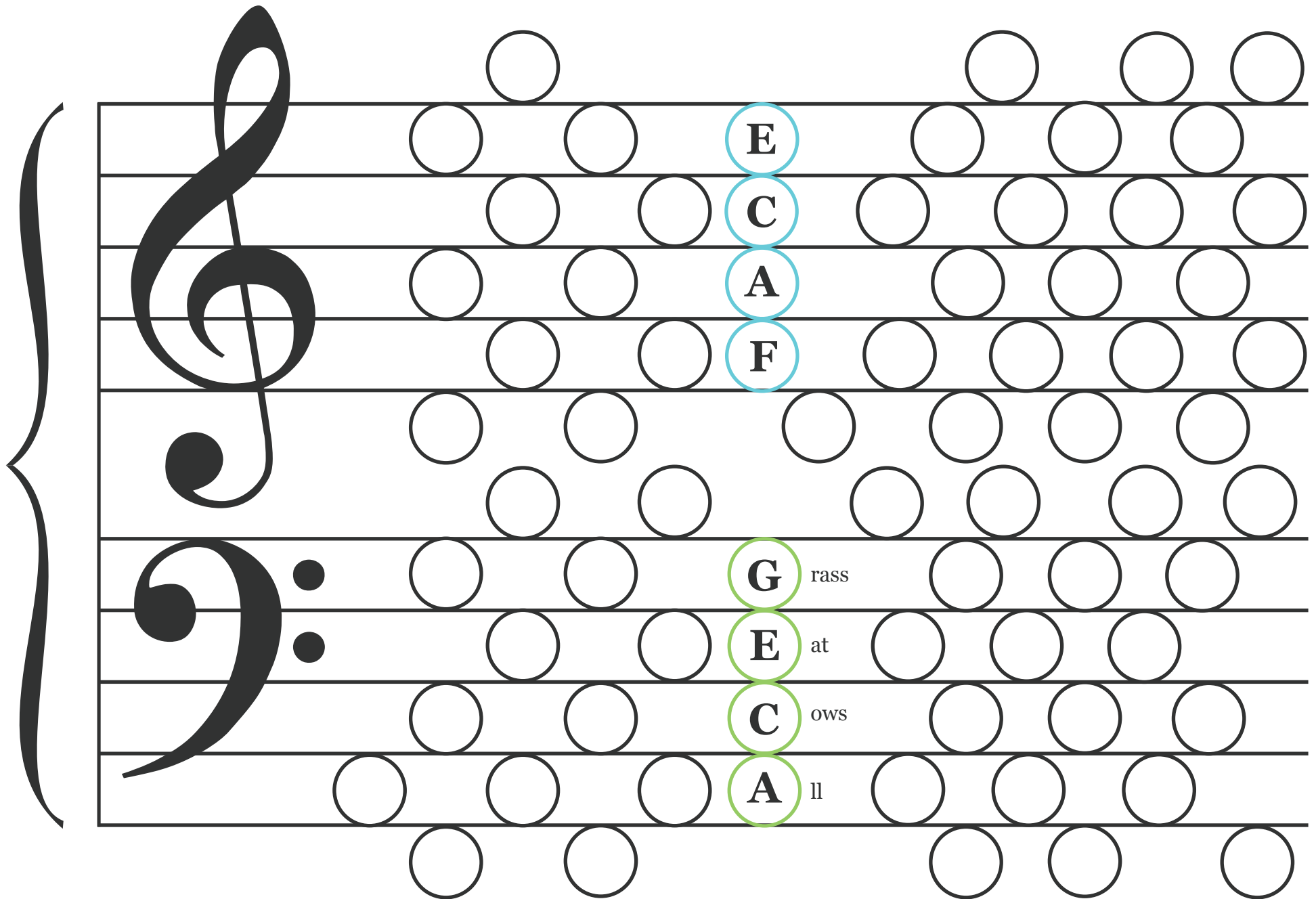

A musical staff with a treble clef and a bass clef. The staff is divided into two systems of four lines each. The top system (treble clef) contains notes E, C, A, and F in the second space of each line, highlighted with a light blue circle. The bottom system (bass clef) contains notes G, E, C, and A in the second space of each line, highlighted with a light green circle. The notes are part of a word search grid. The words 'Grass', 'at', 'Cows', and 'All' are written to the right of the notes G, E, C, and A respectively. The grid consists of 10 columns and 8 rows of circles. The circles are arranged in a regular grid pattern across the staff lines.

E **C** **A** **F**

G r a s s

E a t

C o w s

A l l

Space Notes 8

Plus Their Neighbors

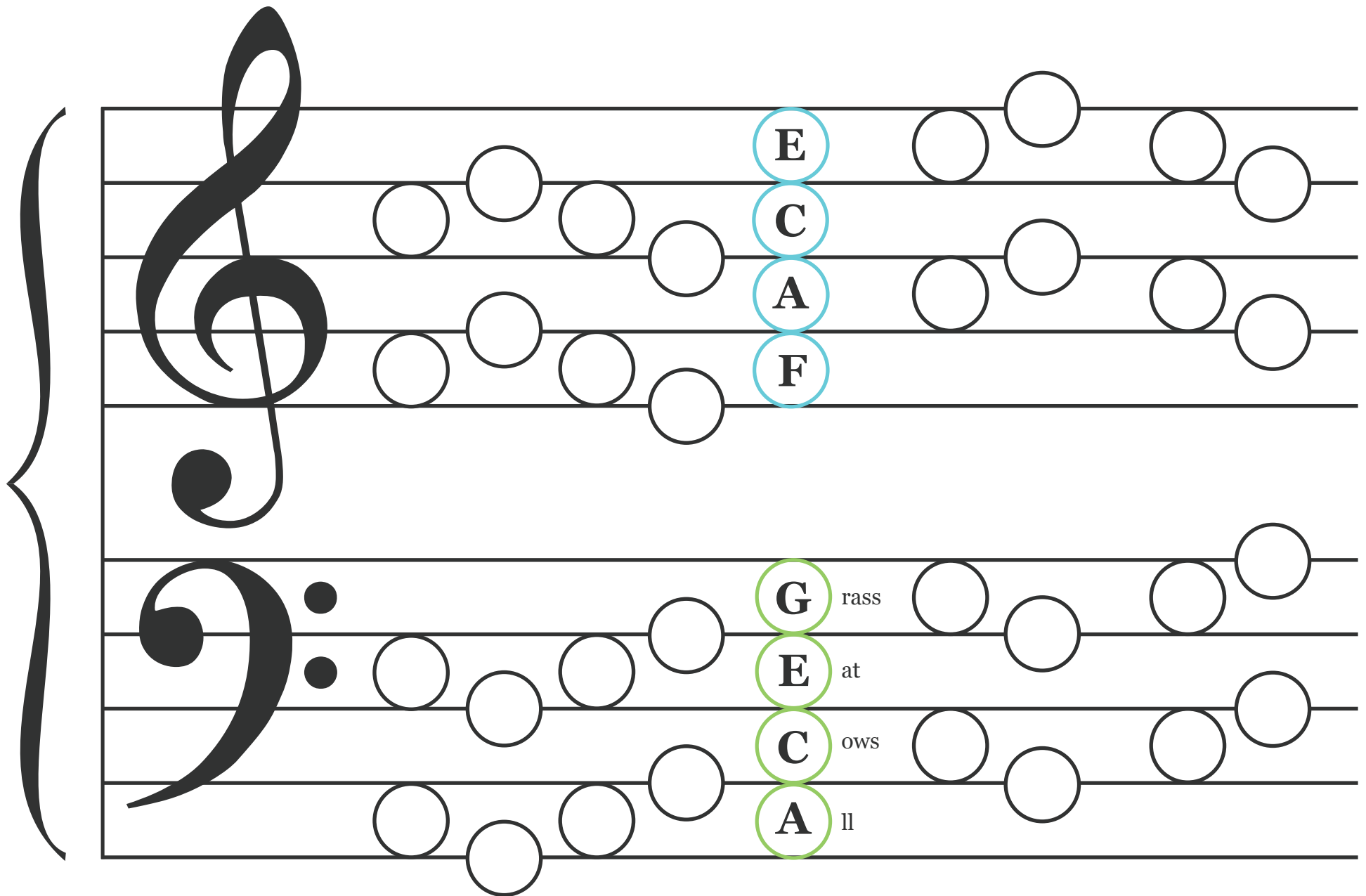

The image shows a musical staff with a treble clef and a bass clef, both connected by a brace on the left. The staff consists of eight lines. The notes are placed in the spaces between the lines. The notes are labeled with letters: E, C, A, F, G, E, C, A. The letters G, E, C, and A are highlighted in green circles, and E, C, A, and F are highlighted in light blue circles.

Line	Notes	Labels
8	Space 7	E
7	Space 6	C
6	Space 5	A
5	Space 4	F
4	Space 3	G
3	Space 2	E
2	Space 1	C
1	Space 0	A

Space Notes 9

Work it Out

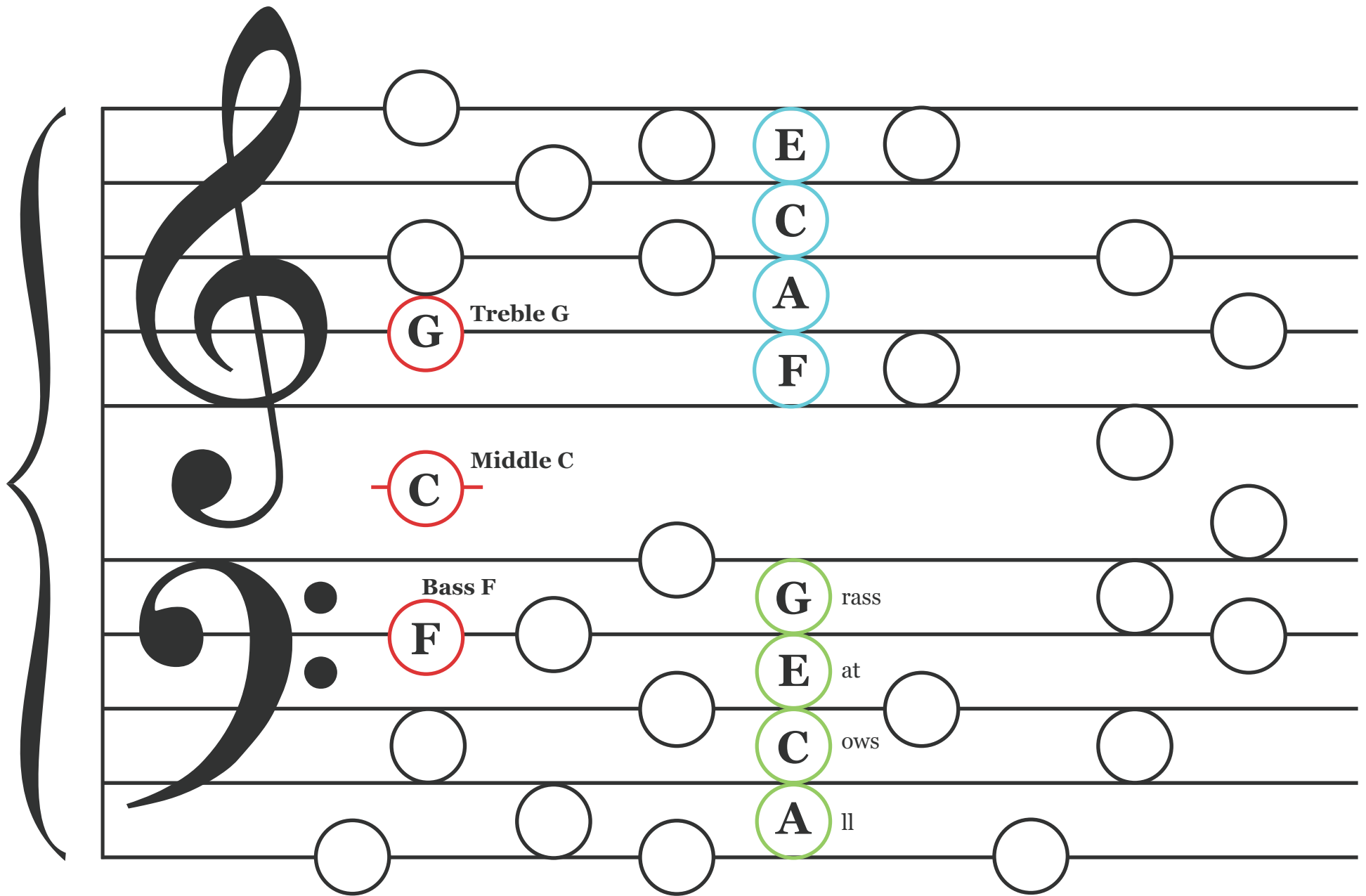

A musical staff with five lines, divided into two systems by a brace on the left. The top system contains a treble clef and four lines. The bottom system contains a bass clef and four lines. The notes are arranged in a descending staircase pattern across the lines. The notes are: Treble G (red circle), Middle C (red circle), Bass F (red circle), Treble E (cyan circle), Treble C (cyan circle), Treble A (cyan circle), Treble F (cyan circle), Middle C (red circle), Bass G (green circle), Bass E (green circle), Bass C (green circle), Bass A (green circle). The notes are labeled with letters and mnemonics: Treble G (G Treble G), Middle C (C Middle C), Bass F (F Bass F), Treble E (E Treble E), Treble C (C Treble C), Treble A (A Treble A), Treble F (F Treble F), Middle C (C Middle C), Bass G (G Bass G), Bass E (E Bass E), Bass C (C Bass C), Bass A (A Bass A).

Space Notes 10

Zig Zag

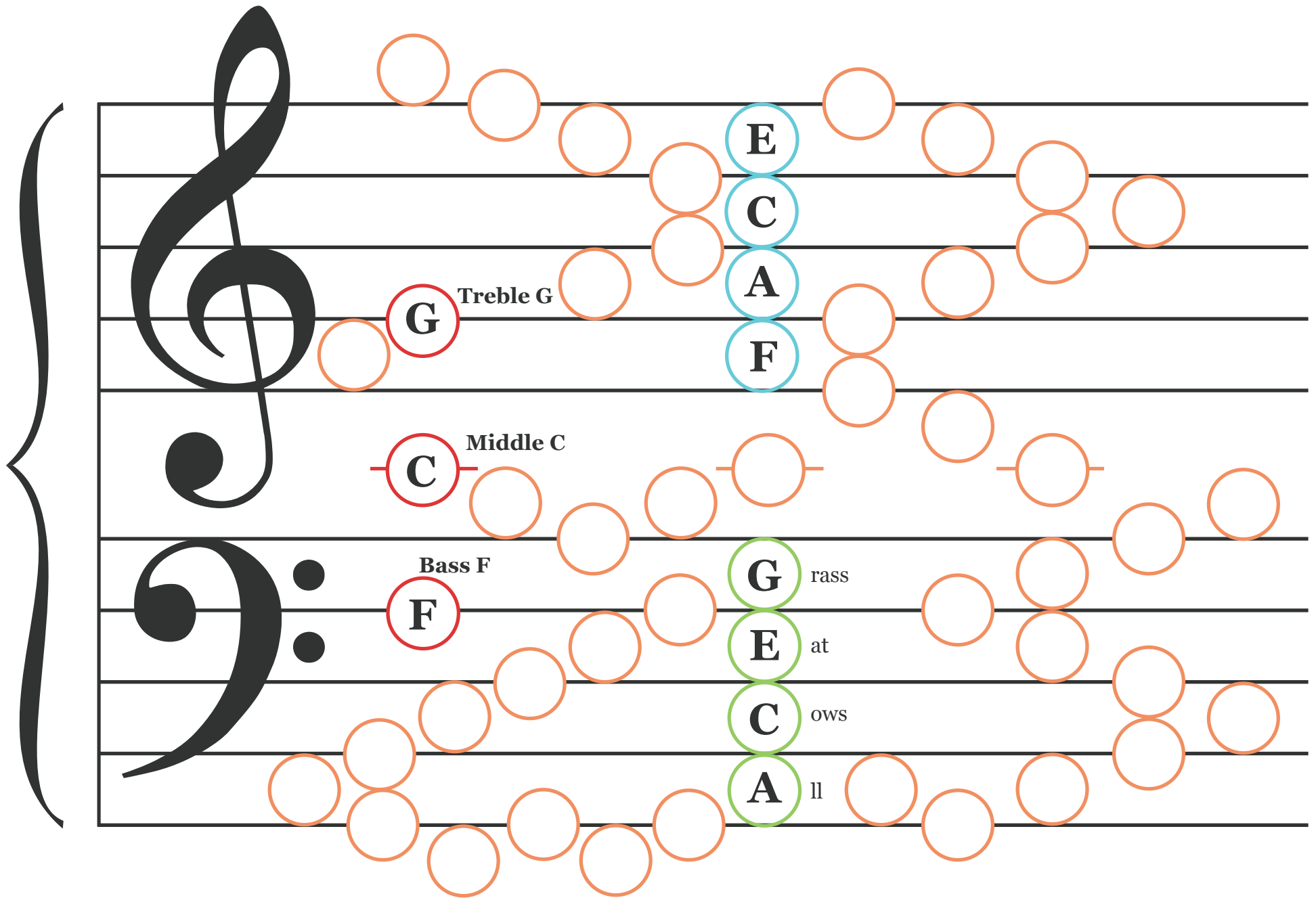

A musical staff with a treble clef and a bass clef, both connected by a brace on the left. The staff consists of eight horizontal lines. A zig-zag pattern of orange circles is drawn across the staff, starting from the top line, moving down to the space below, then up to the next line, and so on. In the center of the staff, a vertical sequence of five notes is highlighted with colored circles: E (top line), C (space), A (line), F (space), and G (line). To the left of this sequence, the notes G, C, F, and A are also highlighted with red circles and labeled: 'Treble G', 'Middle C', 'Bass F', and 'All' respectively. The word 'Gross' is written to the right of the G note in the bass clef section.

E
C
A
F
G Treble G

C Middle C

F Bass F

G Gross
E at
C ows
A ll

Space Notes 11

5th & 6ths

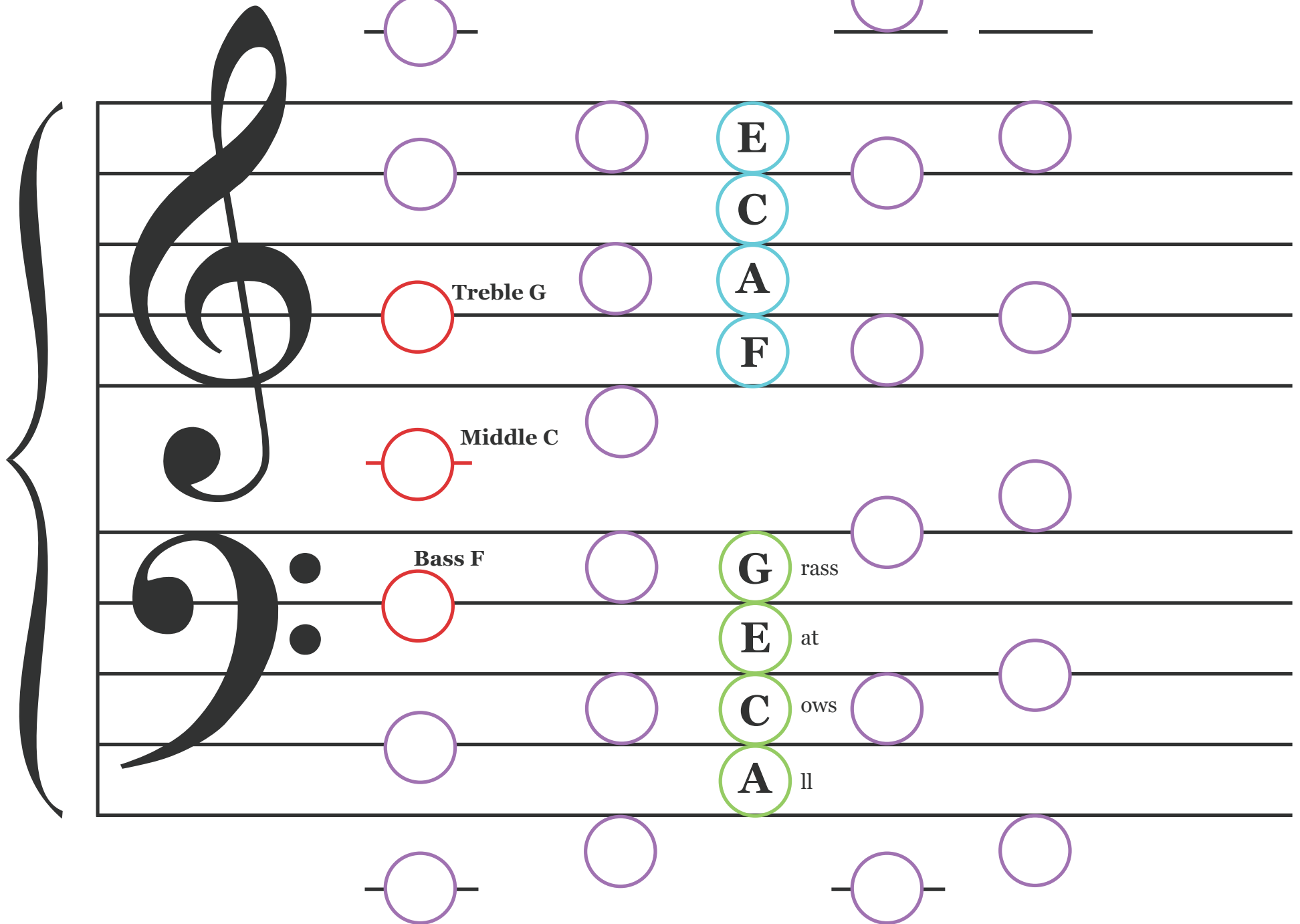

Treble G

Middle C

Bass F

E

C

A

F

G rass

E at

C ows

A ll

The Five C's

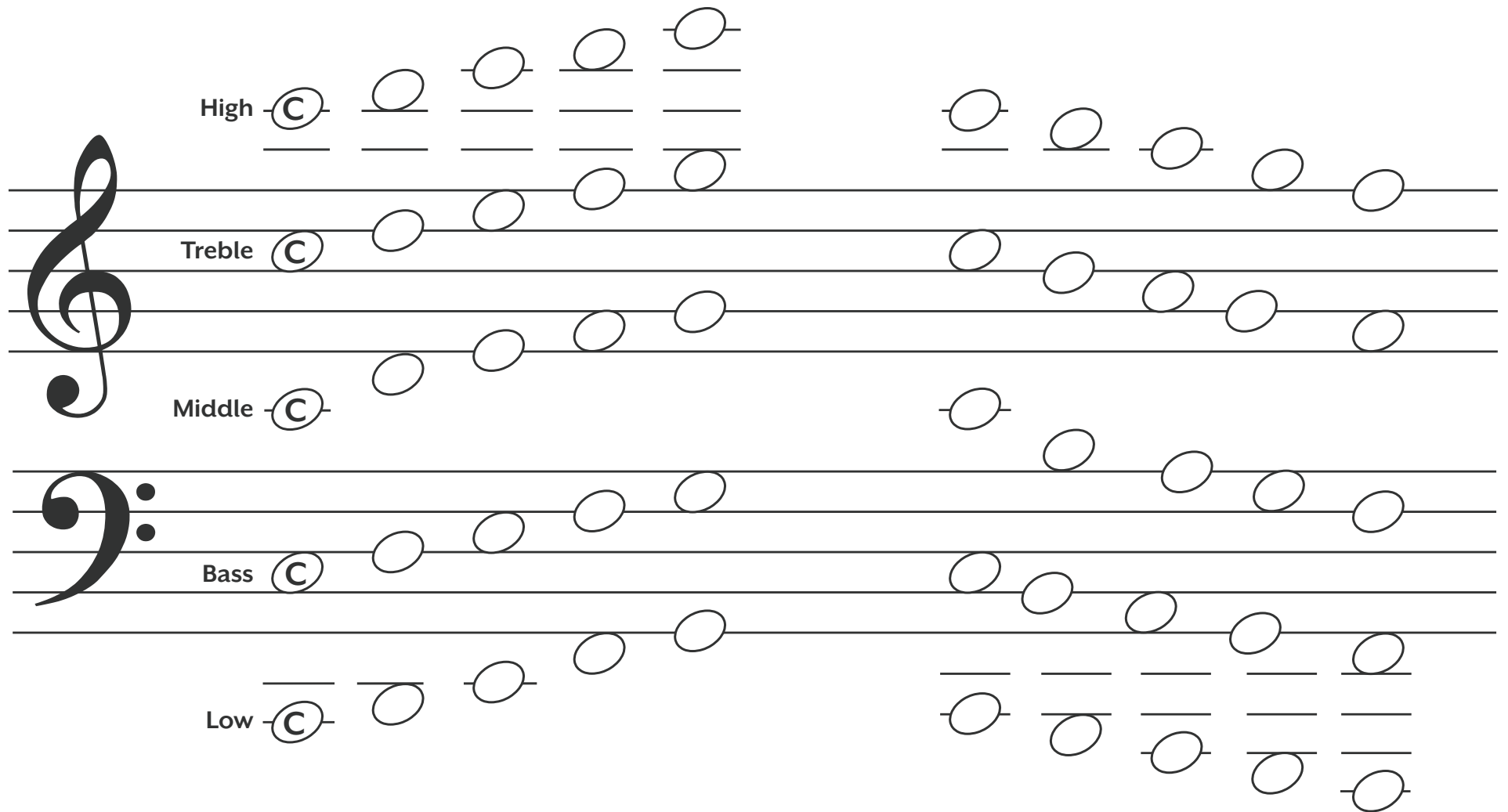

A musical staff consisting of five staves, each with a different clef and a circled 'C' indicating the starting note. The notes are represented by ovals on the staff lines. The staves are labeled as follows:

- High C:** Treble clef, circled 'C' on the first line. Notes are on the first, second, third, fourth, and fifth lines.
- Treble C:** Treble clef, circled 'C' on the second line. Notes are on the second, third, fourth, fifth, and first lines of the next staff.
- Middle C:** Treble clef, circled 'C' on the third line. Notes are on the third, fourth, fifth, first, and second lines of the next staff.
- Bass C:** Bass clef, circled 'C' on the second line. Notes are on the second, third, fourth, fifth, and first lines of the next staff.
- Low C:** Bass clef, circled 'C' on the first line. Notes are on the first, second, third, fourth, and fifth lines.

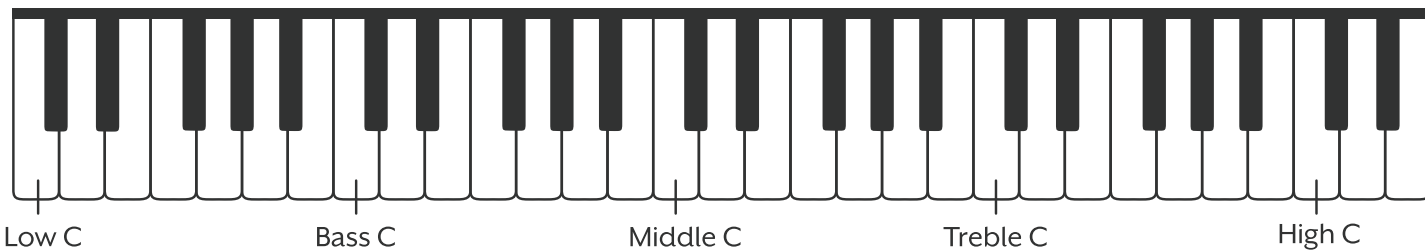

Answer Key

Note Finder 1

Musical staff for Note Finder 1. The staff is divided into three systems: Treble Clef (top), Middle C (middle), and Bass Clef (bottom). The notes are arranged in a piano keyboard layout. The notes G, C, F, A, and E are highlighted in yellow. The notes G, C, F, A, and E are also highlighted in blue. The notes G, C, F, A, and E are also highlighted in red.

Note Finder 2

Musical staff for Note Finder 2. The staff is divided into three systems: Treble Clef (top), Middle C (middle), and Bass Clef (bottom). The notes are arranged in a piano keyboard layout. The notes G, C, F, A, and E are highlighted in yellow. The notes G, C, F, A, and E are also highlighted in blue. The notes G, C, F, A, and E are also highlighted in red. The notes B and D are also highlighted in yellow.

Note Finder 3

Musical staff for Note Finder 3. The staff is divided into three systems: Treble Clef (top), Middle C (middle), and Bass Clef (bottom). The notes are arranged in a piano keyboard layout. The notes E, C, A, G, F, B, and D are highlighted in yellow. The notes E, C, A, G, F, B, and D are also highlighted in blue. The notes E, C, A, G, F, B, and D are also highlighted in red.

Note Finder 4

Musical staff for Note Finder 4. The staff is divided into three systems: Treble Clef (top), Middle C (middle), and Bass Clef (bottom). The notes are arranged in a piano keyboard layout. The notes E, C, A, G, F, B, and D are highlighted in yellow. The notes E, C, A, G, F, B, and D are also highlighted in blue. The notes E, C, A, G, F, B, and D are also highlighted in red. The notes G, C, F, A, and E are also highlighted in yellow.

Note Finder 5

Diagram illustrating Note Finder 5, showing a descending scale of notes across five staves. The notes are highlighted in yellow and include: Treble G (G), Middle C (C), Bass F (F), and various notes in the treble and bass clefs (D, E, F, G, A, B, C).

Note Finder 6

Diagram illustrating Note Finder 6, showing ascending and descending scales of notes across five staves. The notes are highlighted in yellow and include: Treble G (G), Middle C (C), Bass F (F), and various notes in the treble and bass clefs (D, E, F, G, A, B, C).

Note Finder 7

Diagram illustrating Note Finder 7, showing horizontal patterns of notes across five staves. The notes are highlighted in yellow and include: Treble G (G), Middle C (C), Bass F (F), and various notes in the treble and bass clefs (D, E, F, G, A, B, C).

Note Finder 8

Diagram illustrating Note Finder 8, showing ascending and descending scales of notes across five staves. The notes are highlighted in yellow and include: Treble G (G), Middle C (C), Bass F (F), and various notes in the treble and bass clefs (D, E, F, G, A, B, C).

Note Finder 9

Diagram illustrating the placement of notes G, A, B, C, D, E, and F on a grand staff (treble and bass clefs). The notes are arranged in vertical columns across the staves. Key reference points are labeled: Treble G (first line), Middle C (middle C), and Bass F (first space). The notes are color-coded: G (yellow), A (green), B (purple), C (blue), D (orange), E (red), and F (pink).

Note Finder 10

Diagram illustrating a descending scale (G-F-E-D-C-B-A-G) on a grand staff. The notes are arranged in a descending pattern across the staves. Key reference points are labeled: Treble G (first line), Middle C (middle C), and Bass F (first space). The notes are color-coded: G (yellow), F (pink), E (red), D (orange), C (blue), B (purple), A (green), and G (yellow).

Note Finder 11

Diagram illustrating the placement of notes A, B, C, D, E, F, and G on a grand staff. The notes are arranged in vertical columns across the staves. Key reference points are labeled: Treble G (first line), Middle C (middle C), and Bass F (first space). The notes are color-coded: A (green), B (purple), C (blue), D (orange), E (red), F (pink), and G (yellow).

The Five C's

Diagram illustrating the placement of notes C, D, E, F, and G on a grand staff, showing scales starting on High C, Treble C, Middle C, Bass C, and Low C. The notes are arranged in a descending pattern across the staves. Key reference points are labeled: High C, Treble C, Middle C, Bass C, and Low C. The notes are color-coded: C (blue), D (orange), E (red), F (pink), and G (yellow).

Below the staff is a piano keyboard diagram with labels: Low C, Bass C, Middle C, Treble C, and High C.